

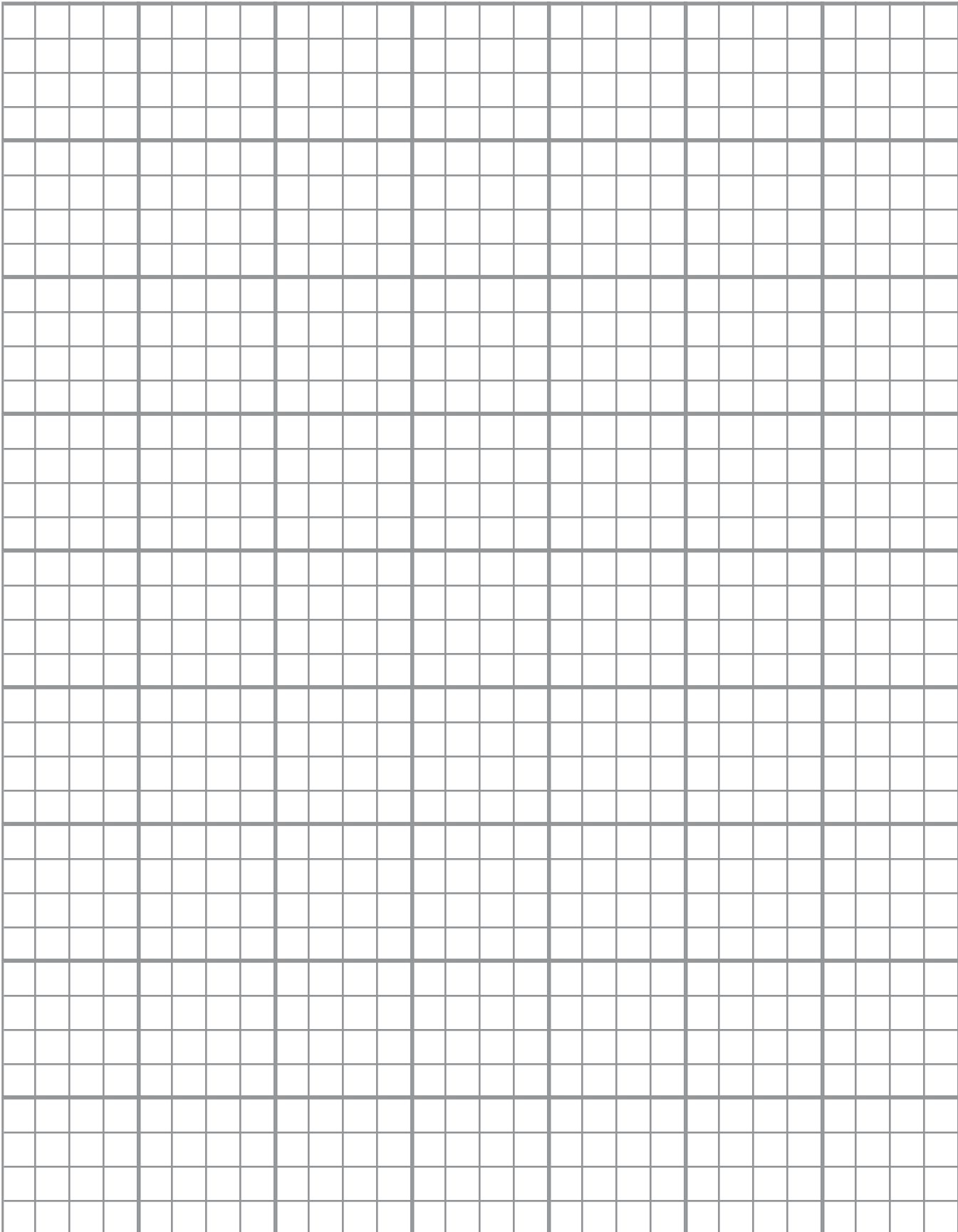

**PROVIDING QUALITY SOLUTIONS FOR THE
AUDIOMETRIC INDUSTRY**





PRODUCT OPTIONS

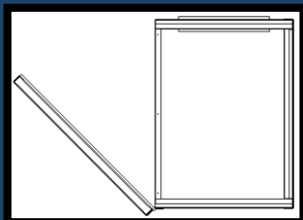

AMB Portable Series: Booths consist of 2 or 3 inch panels with integrated ventilation in the roof and floor.

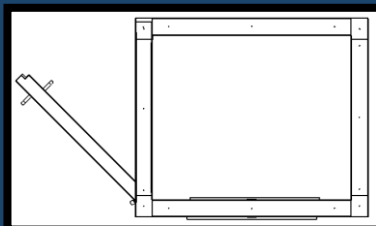

AMB 410: Consists of 4 inch panels with isolated floor and integrated ventilation in roof panel.

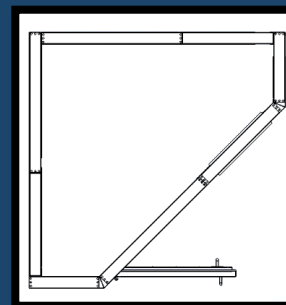

CWR: Designed to save space, the single wall corner room includes 4" panels and isolated floor.

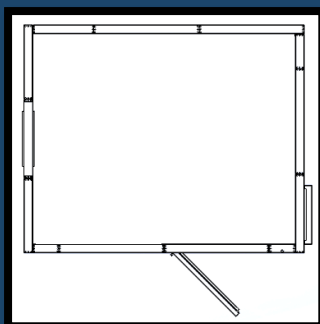

Flex Series: Field configurable rooms consisting of 4 inch single wall panels on an isolated floor, with ventilation panels interchangeable between wall and roof.

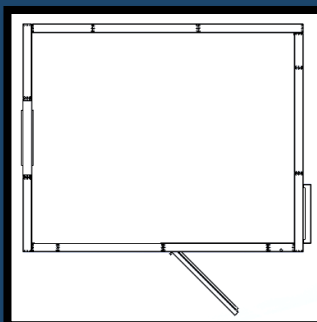

Single Wall Exam Rooms: Customizable rooms consisting of 4 inch wall panels with isolated floor.

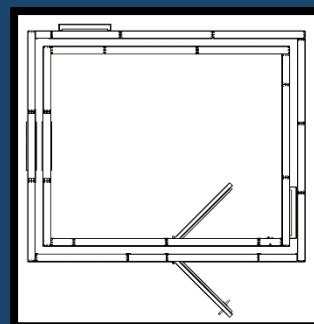

Double Wall Exam Rooms: Customizable rooms consisting of 4 inch wall panels with 4 inch air gap between inner room and outer walls. Exam room sits on isolated floor.

PRODUCT OPTIONS

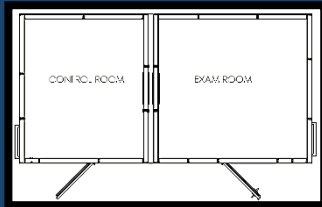

SINGLE WALL CONTROL/EXAM SUITE:

Four inch single wall exam suite. Consists of a control room and exam room with isolated floors, and a 4 inch air gap between rooms

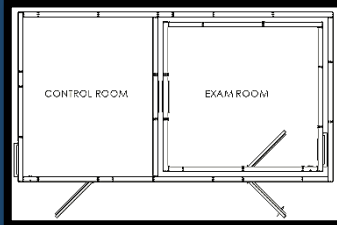

SINGLE WALL CONTROL, DOUBLE WALL EXAM SUITE:

Four inch single wall control and double wall exam suite. Consists of control room, double wall exam room with isolated floors, and a 4 inch air gap around exam room perimeter.

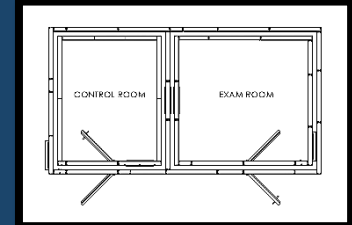

DOUBLE WALL CONTROL/EXAM SUITE:

Four inch double wall control and double wall exam suite. Consists of control room and exam room with isolated floors, and 4 inch air gaps around room perimeters.

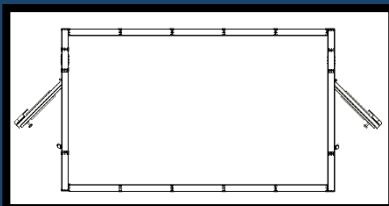

MOBILE EXAM ROOMS:

All booths can be customized for mobile applications. Mobile booths feature heavy duty door hinges and profiles that fit your trailer layout.

FEATURES

Mini Booths

- 6 port plug n play jack panel with 1 ½" cable pass-thru
- 150 lumen, remote controlled led light
- Acoustic floor with 4 locking casters and integrated passive exhaust
- 18" W X 24" L laminated safety glass windows with ¼" glass
- 27" W X 16" L folding equipment shelf
- Integrated roof supply silencer with axial fan
- Carpet
- 12 ft., 12 volt power cord

Exam Rooms

- Plug n Play 12 port jack panel with 1" cable pass-thru
- 650 lumen, 6" led disk light with on/off switch
- Acoustic floor with isolation rails
- Duplex outlets
- 130 cfm, 0.3 sone supply fan with variable control switch
- 24" W X 30" L laminated safety glass window with ¼" glass
- Carpet with cove base trim
- 20 ft. grounded power cord

Precision Audiometrics offers the best quality manufactured booths on the market today. We offer a complete line of audiometric testing booths to serve your needs. Mobile, portable, configurable, single wall, double wall, corner rooms, and exam suites. All booths can be customized to meet your requirements. Audiometric booths delivered on time and manufactured as ordered. At Precision Audiometrics we pride ourselves on delivering audiometric booths to fit our customer's requirements and delivery schedule.

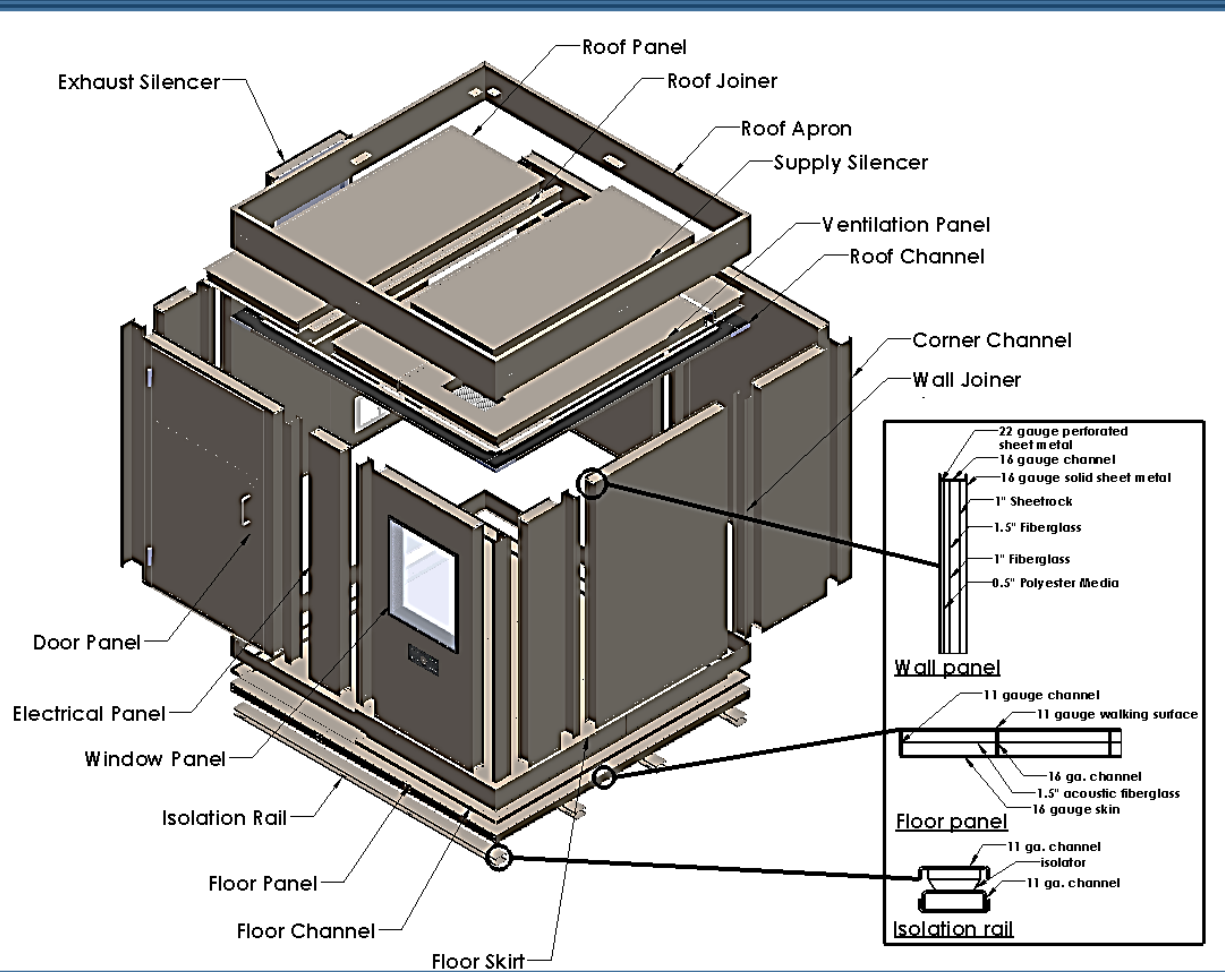

www.precisionaudiometrics.com
 Precision Audiometrics
 1255 E. Hwy. 29
 Bertram TX 78605

Phone: 855-644-8348
 Fax: 512-277-7069
 Email:
 sales@precisionaudiometrics.com

AMB SERIES

The AMB series provide an acoustically isolated environment for various hearing conservation programs including medical, clinical, elementary, and industrial.

FEATURES

	AMB210	AMB310	AMB410
Acoustic floor with four locking casters and integrated passive exhaust	✓	✓	
Plug n Play 6 port jack panel with 1 1/2" cable pass thru	✓	✓	
Plug n Play 12 port jack panel with 1" cable pass thru			✓
Double pane, laminated safety glass window, 18" W X 24" H	✓	✓	
Double pane, laminated safety glass window, 24" W X 30" H			✓
Folding equipment shelf, 16"W X 27"H, with foldable brackets	✓	✓	
Carpeting	✓	✓	✓
150 lumen, remote controlled, led light	✓	✓	
650 lumen, 6" led disk light with light switch			✓
Duplex outlet			✓
Supply fan, roof mounted, with integrated silencer.	✓	✓	✓
Power supplied by 12 ft., 12 volt power cord.	✓	✓	
Power supplied by 20 ft., 120 volt power cord.			✓
Preassembled	✓	✓	
Fits through 3 foot door opening	✓	✓	



AMB210 Shown

We use proprietary solutions for optimal sound deflection, absorption, and maximum durability.

AMB210

Independent Lab Test Results
(per ASTM E 596-96 (2009) and
(ASTM E 413-10))

One-third Octave Center Frequency	NR
Frequency (Hz)	(dB)
250	31
500	29
800	37
1000	40
2000	44
4000	43
NIC	37

SPECIFICATIONS

MODELS	EXTERIOR DIMENSIONS (ft. - in.)			INTERIOR DIMENSIONS (ft. - in.)			DOOR CLEAR OPENING (ft. - in.)		WEIGHT (lbs.)
	W	D	H	W	D	H	W	H	
AMB210	3'-4"	2'-8"	6'-5"	3'-0"	2'-3 1/4"	5'-6"	2'-8"	6'-2"	797
AMB310	3'-4"	2'-8"	6'-5"	2'-9 3/4"	2'-0 1/4"	5'-6"	2'-8"	6'-2"	830
AMB410	4'-0"	4'-8"	7'-1"	3'-3 1/2"	3'-11 3/4"	6'-5"	3'-0"	6'-2"	1300

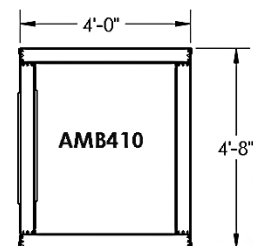
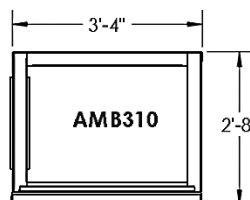
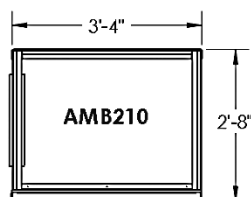

FLEX SERIES

The Flex Series Audiometric test booth consists of panels that are interchangeable to allow for on-site configuration and layout flexibility. These booths can be disassembled, moved, and repositioned as different needs arise. Doors can be configured to swing in or out. Ventilation silencer can be mounted on either roof or wall depending on space constraints. Flex booths are constructed with four-inch thick wall panels and provide significant isolation.

FEATURES:

- 3'-0" X 6'-2" clear opening door
- Double magnetic gasket isolation
- Recessed LED lighting
- Recessed electrical
 - duplex outlet
 - light switch
 - variable speed fan control
- 20' grounded power connection
- Jack panel with 1" cable pass-thru
- Flex silencer panel, can be wall and roof mounted
- 130 cfm, 0.3 sone (@0.1 in. w.g.) supply fan
- Double glazed 2'-0"W X 2'-6", laminated safety glass windows
- Isolated floor
- Floor carpet with cove base trim
- White Texture powder coat
- Flexible installation options, configurable to fit your needs



413FLX Shown

OPTIONAL FEATURES:

(additional charge)

- Door window
- Surface mounted jack panel

SPECIFICATIONS

MODELS	EXTERIOR DIMENSIONS (ft. - in.)			INTERIOR DIMENSIONS (ft. - in.)			DOOR CLEAR OPENING (ft. - in.)		WEIGHT (lbs.)
	W	D	H	W	D	H	W	H	
	411FLX	7'-0"	4'-8"	7'-10"	6'-4"	4'-0"	6'-6"	3'-0"	
412FLX	7'-0"	6'-8"	7'-10"	6'-4"	6'-0"	6'-6"	3'-0"	6'-2"	3300
413FLX	8'-0"	7'-8"	7'-10"	7'-4"	7'-0"	6'-6"	3'-0"	6'-2"	3930

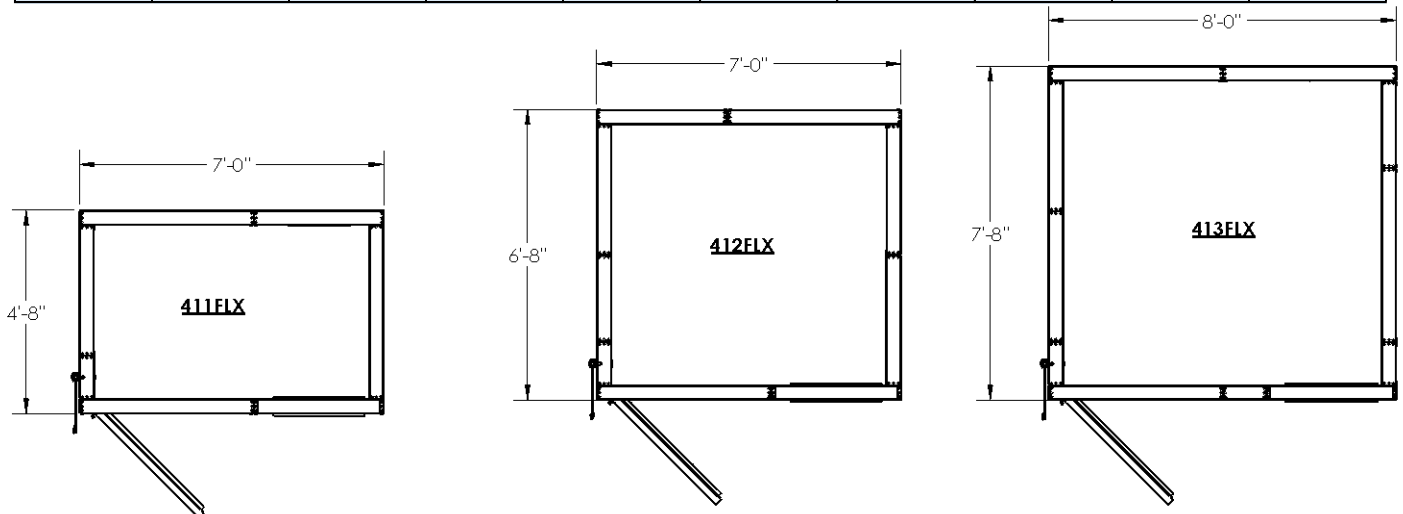

EXAM SUITES

Single wall control with single or double wall exam rooms available to suit your clinical testing needs. Custom sizes are available to fit the customer's space requirements. Exam suites with double wall control and double wall exam rooms are also available. Contact Precision Audiometrics for details.

FEATURES:

- 3'-0" X 6'-2" clear opening doors
- Double magnetic gasket isolation
- Recessed LED lighting
- Recessed electrical
 - duplex outlets
 - light switches
 - variable speed fan controllers
- 20' grounded power connection
- Jack panels with 1" cable pass-thru
- 130 cfm, 0.3 sone (@0.1 in. w.g.) supply fans
- Double glazed 2'-0"W X 2'-6", laminated safety glass windows
- Isolated floors
- Floor carpet with cove base trim
- White Texture powder coat
- Multiple configurations available on all sizes, call for details



OPTIONAL FEATURES:

(additional charge)

- Door windows
- Surface mounted jack panels

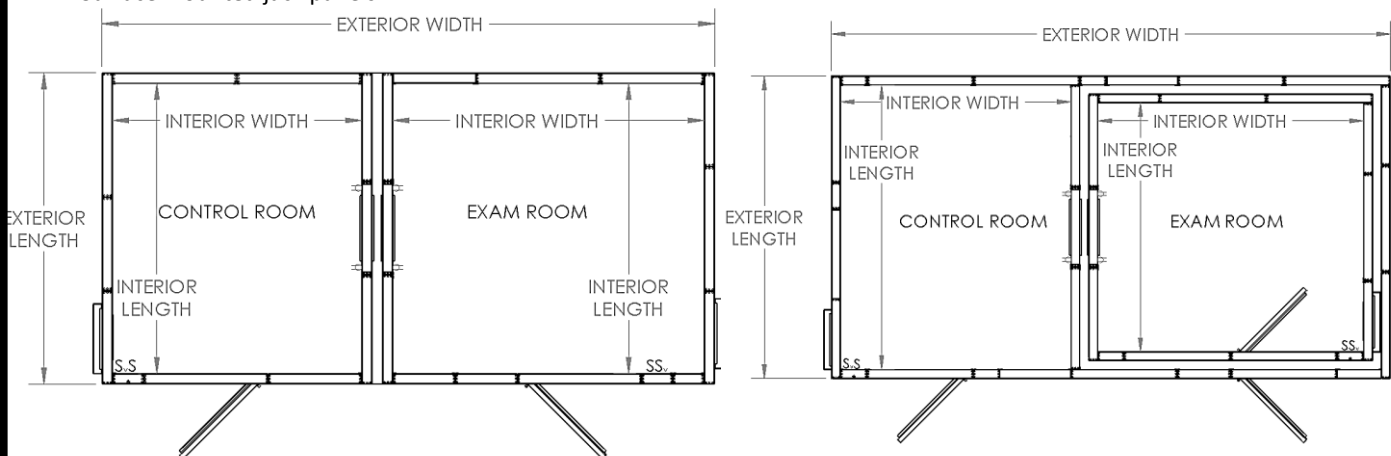

EXAM SUITE	CONTROL ROOM		EXAM ROOM		OVERALL WIDTH	OVERALL LENGTH
	INTERIOR WIDTH	INTERIOR LENGTH	INTERIOR WIDTH	INTERIOR LENGTH		
SCSE50	4'-0"	6'-4"	4'-0"	6'-4"	9'-8"	7'-0"
SCSE63	4'-0"	6'-4"	6'-0"	6'-4"	11'-8"	7'-0"
SCSE69	5'-0"	6'-4"	6'-0"	6'-4"	12'-8"	7'-0"
SCSE82	5'-2"	8'-0"	5'-2"	8'-0"	12'-0"	8'-8"
SCSE88	5'-4"	7'-0"	7'-4"	7'-0"	14'-4"	7'-8"
SCSE121	5'-2"	8'-0"	10'-0"	8'-0"	16'-10"	8'-8"
SCSE133	7'-0"	8'-4"	9'-0"	8'-4"	17'-8"	9'-0"
SCSE168	8'-0"	9'-4"	10'-0"	9'-4"	19'-8"	10'-0"

EXAM SUITE	CONTROL ROOM		EXAM ROOM		OVERALL WIDTH	OVERALL LENGTH
	INTERIOR WIDTH	INTERIOR LENGTH	INTERIOR WIDTH	INTERIOR LENGTH		
ES56	4'-0"	7'-8"	4'-0"	6'-4"	10'-4"	8'-4"
ES82	6'-0"	7'-4"	6'-4"	6'-0"	14'-8"	8'-0"
ES94	5'-8"	9'-4"	5'-2"	8'-0"	13'-2"	10'-0"
ES110	7'-0"	8'-4"	7'-4"	7'-0"	16'-8"	9'-0"
ES144	5'-8"	11'-4"	8'-0"	10'-0"	16'-0"	12'-0"
ES150	7'-8"	9'-8"	9'-0"	8'-4"	19'-0"	10'-4"
ES186	8'-8"	10'-8"	10'-0"	9'-4"	21'-0"	11'-4"

CONTROL ROOM: 7'-2"	OVERALL HEIGHT: 8'-7"
INTERIOR HEIGHT: CONTROL ROOM: 6'-6"	EXAM ROOM: 6'-6"
OVERALL HEIGHT: 7'-10"	

SINGLE AND DOUBLE WALL EXAM ROOMS

Single and double wall exam rooms provide the required interior acoustically isolated environment for various hearing conservation programs including medical, clinical, elementary and industrial.

FEATURES:

- 3'-0" X 6'-2" clear opening doors
- Double magnetic gasket isolation
- Recessed LED lighting
- Recessed electrical
 - duplex outlets
 - light switches
 - variable speed fan controllers
- 20' grounded power connection
- Jack panels with 1" cable pass-thru
- 130 cfm, 0.3 sone (@0.1 in. w.g.) supply fan
- Double glazed 2'-0"W X 2'-6", laminated safety glass windows
- Isolated floors
- Floor carpet with cove base trim
- White Texture powder coat
- Multiple configurations available on all sizes, call for details

OPTIONAL FEATURES:

(additional charge)

- Door windows
- Surface mounted jack panels

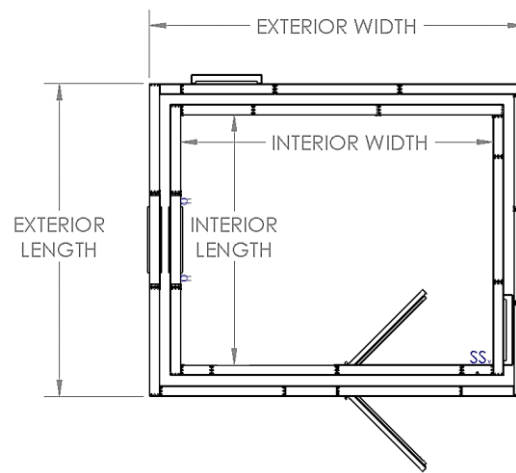
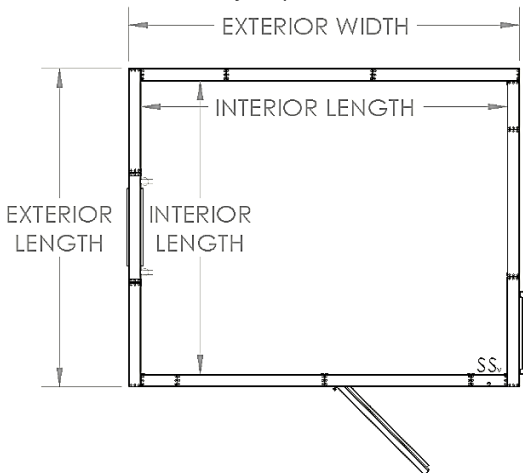

SINGLE WALL EXAM	EXAM ROOM		OVERALL WIDTH	OVERALL LENGTH
	INTERIOR WIDTH	INTERIOR LENGTH		
SE29	4'-0"	3'-4"	4'-8"	4'-0"
SE104	6'-4"	6'-0"	7'-0"	6'-8"
SE122	6'-0"	6'-4"	6'-8"	7'-0"
SE165	7'-4"	7'-0"	8'-0"	7'-8"
SE211	9'-0"	8'-4"	9'-8"	9'-0"
SE143	10'-0"	9'-4"	10'-8"	10'-0"
SE113	8'-0"	5'-2"	8'-8"	5'-10"
SE200	10'-0"	8'-0"	10'-8"	8'-8"
INTERIOR HEIGHT: 6' - 6"			OVERALL HEIGHT: 7'-10"	

DOUBLE WALL EXAM	EXAM ROOM		OVERALL WIDTH	OVERALL LENGTH
	INTERIOR WIDTH	INTERIOR LENGTH		
DE29	4'-0"	3'-4"	6'-0"	5'-4"
DE104	6'-4"	6'-0"	8'-4"	8'-0"
DE122	6'-0"	6'-4"	9'-4"	9'-0"
DE165	7'-4"	7'-0"	11'-0"	10'-4"
DE211	9'-0"	8'-4"	12'-0"	11'-4"
DE143	10'-0"	9'-4"	8'-4"	6'-0"
DE113	8'-0"	5'-2"	10'-0"	7'-2"
DE200	10'-0"	8'-0"	12'-0"	10'-0"
INTERIOR HEIGHT: 6' - 6"			OVERALL HEIGHT: 8'-7"	

CORNER WALL EXAM ROOMS

The space saving corner wall room provides a comfortable interior exam space, while freeing up additional exterior office space.

FEATURES:

- 3'-0" X 6'-2" clear opening doors
- Double magnetic gasket isolation
- Recessed LED lighting
- Recessed electrical
 - duplex outlets
 - light switches
 - variable speed fan controllers
- 20' grounded power connection
- Jack panels with 1" cable pass-thru
- 130 cfm, 0.3 sone (@0.1 in. w.g.) supply fan
- Double glazed 2'-0"W X 2'-6", laminated safety glass windows
- Isolated floor
- Floor carpet with cove base trim
- White Texture powder coat
- Multiple configurations available on all sizes, call for details

OPTIONAL FEATURES:

(additional charge)

- Door window
- Surface mounted jack panels

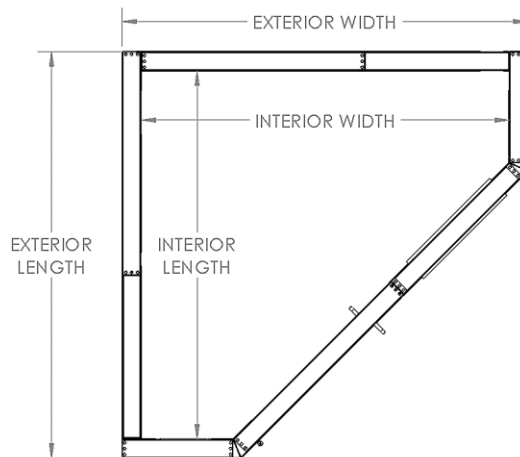

CWR	EXAM ROOM		OVERALL WIDTH	OVERALL LENGTH
	INTERIOR WIDTH	INTERIOR LENGTH		
CWR13	4'-0"	3'-4"	6'-0"	5'-4"
CWR38	6'-4"	6'-0"	8'-4"	8'-0"
INTERIOR HEIGHT: 6' - 6"			OVERALL HEIGHT: 7'-10"	

